

## Crafter 50 Pick-up Dubbele Cabine L3H1

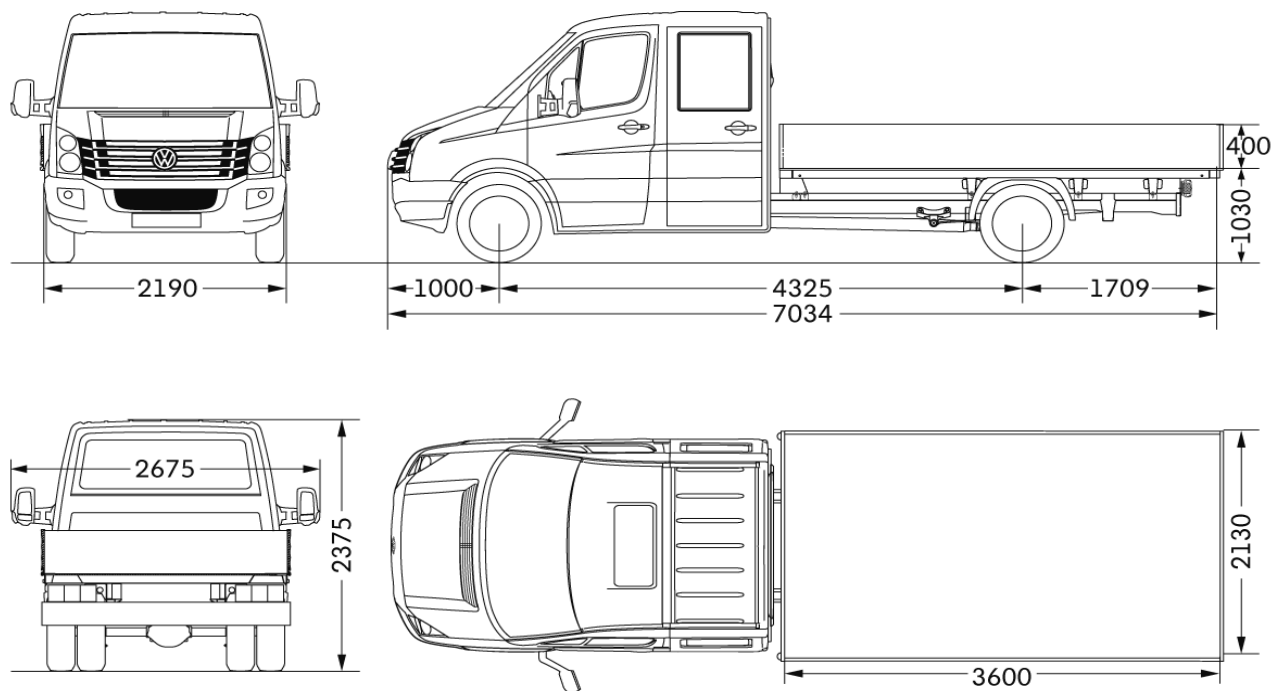

### Afmetingen

Oppervlakte laadbak (m <sup>2</sup> )	7,7
Draaicirkel over de bumper (m)	15,6
Inhoud brandstoftank (l)	75 liter (Materiaal: kunststof)

### Gewichten

	Crafter 50 (3,5t)	Crafter 50
Max. toelaatbaar totaalgewicht (GVW)	3.500 kg	5.000 kg
Leeggewicht * (incl. halve tank diesel, excl. bestuurder en evt. standaard- of meeruitv.)	2.334 kg	2.334 kg
<b>LAADVERMOGEN</b>	1.166 kg	2.666 kg
Max. toelaatbaar aslast voor	1.850 kg	1.850 kg
Max. toelaatbaar aslast achter	2.300 kg	3.500 kg
Max. daklast	100 kg	100 kg
Max. kogeldruk	140 kg	140 kg

### Max. toelaatbaar AHW-gewicht / Treingewicht i.c.m achterasoverbrengingen, in kg

	3,692:1	3,923:1	4,182:1	4,364:1	4,727:1	5,1:1
<b>Crafter 50 (3,5t)</b>						
2.0 TDI 80kW / 109pk			2.000/ 5.500 <sup>3</sup>	3.500/ 7.000 <sup>1</sup>	3.500/ 7.000	
2.0 TDI 105kW / 143pk			2.000/ 5.500 <sup>3</sup>	3.500/ 7.000 <sup>1</sup>	3.500/ 7.000	
2.0 TDI 120kW / 164pk	2.000/ 5.500 <sup>3</sup>	3.500/ 7.000 <sup>1</sup>	3.500/ 7.000			
<b>Crafter 50</b>						
2.0 TDI 80kW / 109pk					3.500/ 7.000 <sup>3</sup>	3.500 / 7.000 <sup>1</sup>
2.0 TDI 105kW / 143pk					3.500/ 7.000 <sup>3</sup>	3.500 / 7.000 <sup>1</sup>
2.0 TDI 120kW / 164pk			3.500/ 7.000 <sup>3</sup>	3.500/ 7.500 <sup>1</sup>	3.500 / 8.000	3.500 / 8.000

<sup>1</sup> = standaard achterasoverbrenging

<sup>3</sup> = standaard achterasoverbrenging BMT

\* Let op: Leeggewicht is exclusief enkele standaard- en/of meeruitvoeringen zoals Airco= 25 kg, reservewiel = 30 kg, radiovoorb. = 2 kg

### Electrische installatie

Accu	100 Ah 450 A
Dynamo	110 A

Motorisering	80kW / 109pk (met BMT)	105kW / 143pk (met BMT)	120kW / 164pk (met BMT)					
Aantal cilinders	4							
Cilinderinhoud, cm <sup>3</sup>	1968							
Boring/slag	81,0/95,5							
Compressie	16:01							
Aandrijving	Tandriem							
Kleppen per cilinder	4							
Vermogen	80kW (109pk) / 3.500	105kW (143pk) / 3.500	120kW (164pk) / 3.600					
Koppel	300 / 1.500-2.250	340 / 1.575-2.250	400 / 1.800					
Mengselvorming	Common-Rail (directe inspuiting)							
Uitlaatgasnorm	EURO V met dieselroetfilter							
Uitlaatgasnorm	EEV	EEV	EEV					
<b>Overbrengingen (voor handmatige 6-versnellingsbak)</b>								
	1 <sup>e</sup> versn.	2 <sup>e</sup> versn.	3 <sup>e</sup> versn.	4 <sup>e</sup> versn.	5 <sup>e</sup> versn.	6e versn.	Achteruit	Aandrijving
Overbrenging	5,076	2,610	1,518	1,000	0,791	0,675	-4,722	Achter
<b>Onderstel</b>								
Voorwielophanging	Dwarsgeplaatste wieldraagarm met bladveer en stabilisator							
Achterwielophanging	Starre as met bladveer							
Remmen	Schijfremmen (diameter voor 300mm, achter 298mm) met standaard ABS / ASR / ESP							
Banden	195/75 R16							
Velgen	5,5J x 16							
<b>Crafter 50 (3,5t) topsnelheid (km/h) bij achterasoverbrengingen</b>								
	<b>3,692:1</b>	<b>3,923:1</b>	<b>4,182:1</b>	<b>4,364:1</b>	<b>4,727:1</b>	<b>5,1:1</b>		
2.0 TDI 80kW/ 109pk			134	132	132			
2.0 TDI 105kW / 143pk								
2.0 TDI 120kW/ 164pk	148	146	143					
<b>Crafter 50 topsnelheid (km/h) bij achterasoverbrengingen</b>								
	<b>3,692:1</b>	<b>3,923:1</b>	<b>4,182:1</b>	<b>4,364:1</b>	<b>4,727:1</b>	<b>5,1:1</b>		
2.0 TDI 80kW/ 109pk					90	90		
2.0 TDI 105kW / 143pk					90	90		
2.0 TDI 120kW/ 164pk			90	90	90			

